

## Automatic compensation of position errors in assembling process!

Center Master is a unique device that enables the automatic compensation of position and angle errors in component assembly errors using multiple elastomer shear pads (ESPs) on the principle of Remote Center Compliance (RCC) developed and tested at the Massachusetts Institute of Technology (MIT) in the U.S. It can be used for a broad range of applications from precision component insertion operation by robots or dedicated machines to press fitting operation applying a load of 100 kN or more.

Reduce assembly failures caused by centering errors

Reduce man-hours at initial installation and simplify maintenance process

Improve assembly quality by automatically compensating position errors

Reduce the risk of machine failure caused by unbalanced load

### Misalignment correction mechanism

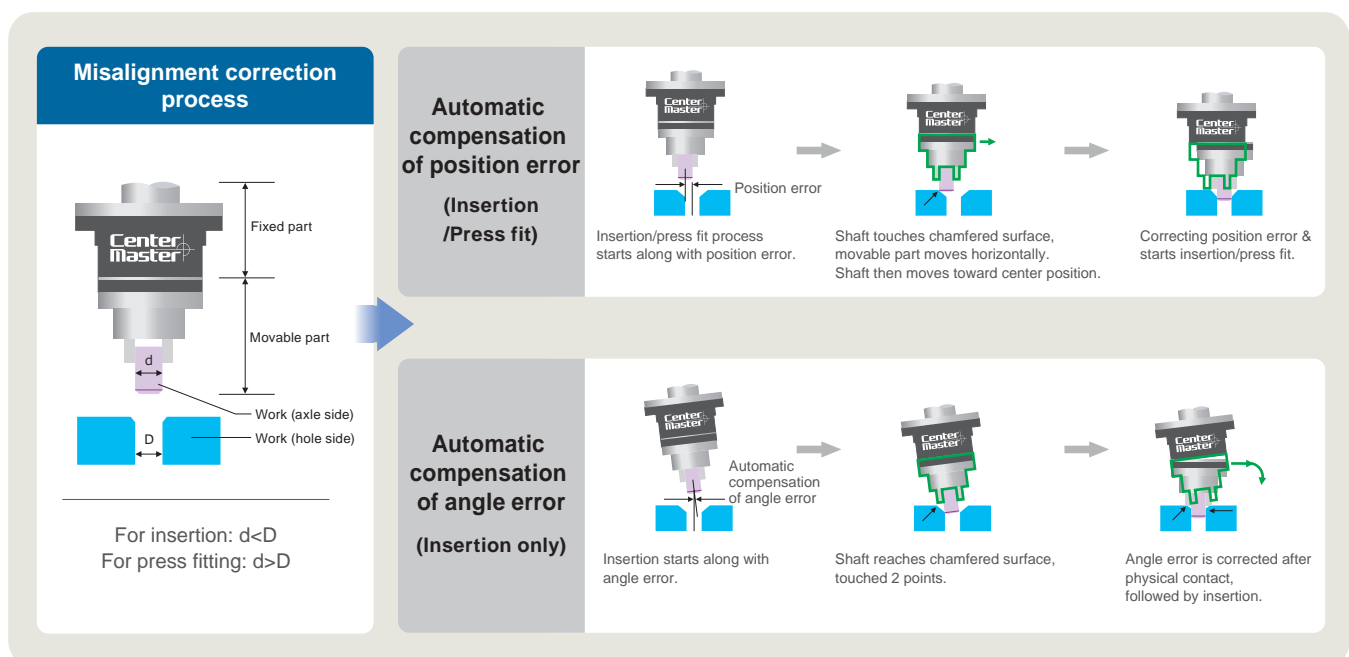

**A Series**  
(insertion)



Model	Rated capacity <sup>*1</sup> [N]	Elastic center distance P [mm]	Allowable payload <sup>*1</sup> [N]	Error correction range			Elastic coefficient <sup>*2</sup>				Product weight [kg]
				Position error [mm]	Angular error [deg]	Torsion error [deg]	Axial direction [N/mm]		Horizontal direction [N/mm]	Torsion error [Nm/rad]	
							Compression	Tension			
A6-030-040	186	30	14.7	±2	±2	—	625.9	100.1	9.8	2.2	0.1
A6-040-048	255	40	14.7	±2	±2	±7.7	625.9	143.2	9.8	2.4	0.1
A6-050-054	353	50	19.6	±2	±2	±7.3	1182.1	143.2	11.8	3.0	0.2
A6-060-060	353	60	19.6	±2	±2	±6.0	1182.1	143.2	11.8	3.0	0.2
A6-070-065	471	70	26.5	±2	±2	±6.6	1575.5	191.3	11.8	4.2	0.2
A6-080-070	471	80	26.5	±2	±2	±6.2	1575.5	191.3	11.8	4.2	0.3
A6-090-078	363	90	37.3	±2	±2	±5.5	1218.4	225.6	12.8	6.1	0.4
A6-100-084	363	100	37.3	±2	±2	±5.0	1218.4	225.6	12.8	6.1	0.4
A6-110-088	363	110	38.3	±2	±2	±4.6	1218.4	225.6	12.8	7.0	0.4
A6-120-095	363	120	38.3	±2	±2	±5.1	1218.4	225.6	12.8	7.0	0.5
A6-130-099	363	130	38.3	±2	±2	±5.1	1218.4	225.6	12.8	7.0	0.5
A6-140-108	549	140	78.5	±2	±2	±4.8	1842.3	408.1	14.7	7.7	0.7
A6-150-130	824	150	78.5	±2	±2	±4.2	1842.3	408.1	14.7	7.7	1.0

**LA Series**  
(insertion, airlock type)



Model	Rated capacity <sup>*1</sup> [N]	Elastic center distance P [mm]	Allowable payload <sup>*1</sup> [N]	Error correction range			Elastic coefficient <sup>*2</sup>				Air pressure <sup>*3</sup> [MPa]	Tube ext. diameter [mm]	Product weight [kg]
				Position error [mm]	Angular error [deg]	Torsion error [deg]	Axial direction [N/mm]		Horizontal direction [N/mm]	Torsion error [Nm/rad]			
							Compression	Tension					
LA6-060-060	353	60	19.6	±2	±2	±6.0	1182.1	143.2	11.8	3.0	0.5	φ4	0.2
LA6-070-065	471	70	26.5	±2	±2	±6.6	1575.5	191.3	11.8	4.2			0.3
LA6-080-070	471	80	26.5	±2	±2	±6.2	1575.5	191.3	11.8	4.2			0.3
LA6-090-078	363	90	37.3	±2	±2	±5.5	1218.4	225.6	12.8	6.1			0.4
LA6-100-084	363	100	37.3	±2	±2	±5.0	1218.4	225.6	12.8	6.1			0.5
LA6-110-088	363	110	38.3	±2	±2	±4.6	1218.4	225.6	12.8	7.0			0.5
LA6-120-095	363	120	38.3	±2	±2	±5.1	1218.4	225.6	12.8	7.0			0.6
LA6-130-099	363	130	38.3	±2	±2	±5.1	1218.4	225.6	12.8	7.0			0.6
LA6-140-108	549	140	78.5	±2	±2	±4.8	1842.3	408.1	14.7	7.7			0.8
LA6-150-130	824	150	78.5	±2	±2	±4.2	1842.3	408.1	14.7	7.7			1.6

**S Series**  
(press-fitting, load cell, flange)



Model	Rated capacity <sup>*1</sup> [N]	Elastic center distance P [mm]	Allowable payload <sup>*1</sup> [N]	Error correction range		Elastic coefficient <sup>*2</sup>				Product weight [kg]
				Position error [mm]	Torsion error [deg]	Axial direction [N/mm]		Horizontal direction [N/mm]	Torsion error [Nm/rad]	
						Compression	Tension			
S4D-070-065-02	19.6	70	29.4	±2	±6.6	1575.5	191.3	11.8	4.2	1.4
S4D-070-065-04	39.2									
S4D-070-065-06	58.9									
S4D-090-078-02	19.6	90	40.2	±2	±5.5	1218.4	225.6	12.8	6.1	2.1
S4D-090-078-04	39.2									
S4D-090-078-06	58.9									
S4D-110-088-03	29.4	110	40.2	±2	±4.6	1218.4	225.6	12.8	7.0	2.7
S4D-110-088-06	58.9									
S4D-110-088-10	98.1									
S4D-140-108-03	29.4	140	80.4	±2	±4.8	1842.3	408.1	14.7	7.7	4.1
S4D-140-108-06	58.9									
S4D-140-108-10	98.1									
S4D-150-130-04	39.2	150	80.4	±2	±4.2	1842.3	408.1	14.7	7.7	6.0
S4D-150-130-07	68.7									
S4D-150-130-12	117.7									

**SS Series**  
(press fit, integrated load cell, flangeless type)



Model	Rated capacity <sup>*1</sup> [N]	Elastic center distance P [mm]	Allowable payload <sup>*1</sup> [N]	Error correction range		Elastic coefficient <sup>*2</sup>				Product weight [kg]
				Position error [mm]	Torsion error [deg]	Axial direction [N/mm]		Horizontal direction [N/mm]	Torsion error [Nm/rad]	
						Compression	Tension			
SS4D-070-065-02	19.6	70	29.4	±2	±6.6	1575.5	191.3	11.8	4.2	1.2
SS4D-070-065-04	39.2									
SS4D-070-065-06	58.9									
SS4D-090-078-02	19.6	90	40.2	±2	±5.5	1218.4	225.6	12.8	6.1	1.7
SS4D-090-078-04	39.2									
SS4D-090-078-06	58.9									
SS4D-110-088-03	29.4	110	40.2	±2	±4.6	1218.4	225.6	12.8	7.0	2.3
SS4D-110-088-06	58.9									
SS4D-110-088-10	98.1									
SS4D-140-108-03	29.4	140	80.4	±2	±4.8	1842.3	408.1	14.7	7.7	3.5
SS4D-140-108-06	58.9									
SS4D-140-108-10	98.1									
SS4D-150-130-04	39.2	150	80.4	±2	±4.2	1842.3	408.1	14.7	7.7	5.4
SS4D-150-130-07	68.7									
SS4D-150-130-12	117.7									

\*1 Rated capacity & allowance load: Do contact us if it exceeds the value written in specifications.

\*2 Elastic coefficient: Elasticity at Elastic center (P). It is the average value until stopper inside CenterMaster is activated.

\*3 Air pressure: Recommended pressure so that end effector does not vibrate when robot arm moves.

\* CenterMaster corrects max. ±2 mm position error. This value varies depending on size of chamfered surface.

Please avoid using in an environment that will corrode the interior of this product.

Line-up is as of Feb 2023. Contact us for custom orders.

Model	Dimensions [mm]														
	A	B	C	D	E	F	G	H	I	J	K	L	M	N	O
A6-030-040	3	φ4.5	φ8	2	30	φ40	—	5	30	5	—	φ40	3	M5	30
A6-040-048	3	φ5.5	φ9.5	2	36	φ48	φ12 <sup>+0.02</sup> <sub>-0</sub>	6	30	6	φ12 <sup>+0.02</sup> <sub>-0</sub>	φ48	3	M6	36
A6-050-054	3	φ5.5	φ9.5	3	43	φ54	φ12 <sup>+0.02</sup> <sub>-0</sub>	7	38	7	φ12 <sup>+0.02</sup> <sub>-0</sub>	φ54	3	M6	43
A6-060-060	3	φ5.5	φ9.5	3	48	φ60	φ12 <sup>+0.02</sup> <sub>-0</sub>	7	39	7	φ12 <sup>+0.02</sup> <sub>-0</sub>	φ60	3	M6	48
A6-070-065	4	φ5.5	φ9.5	3	54	φ65	φ12 <sup>+0.02</sup> <sub>-0</sub>	7	39	7	φ12 <sup>+0.02</sup> <sub>-0</sub>	φ65	4	M6	54
A6-080-070	4	φ5.5	φ9.5	3	58	φ70	φ12 <sup>+0.02</sup> <sub>-0</sub>	7	39	7	φ12 <sup>+0.02</sup> <sub>-0</sub>	φ70	4	M6	58
A6-090-078	4	φ6.6	φ11	4	65	φ78	φ16 <sup>+0.02</sup> <sub>-0</sub>	8	43	8	φ16 <sup>+0.02</sup> <sub>-0</sub>	φ78	4	M8	65
A6-100-084	4	φ6.6	φ11	4	70	φ84	φ16 <sup>+0.02</sup> <sub>-0</sub>	8	43	8	φ16 <sup>+0.02</sup> <sub>-0</sub>	φ84	4	M8	70
A6-110-088	4	φ6.6	φ11	4	75	φ88	φ16 <sup>+0.02</sup> <sub>-0</sub>	8	43	8	φ16 <sup>+0.02</sup> <sub>-0</sub>	φ88	4	M8	75
A6-120-095	4	φ6.6	φ11	4	80	φ95	φ16 <sup>+0.02</sup> <sub>-0</sub>	8	43	8	φ16 <sup>+0.02</sup> <sub>-0</sub>	φ95	4	M8	80
A6-130-099	4	φ6.6	φ11	4	85	φ99	φ16 <sup>+0.02</sup> <sub>-0</sub>	8	43	8	φ16 <sup>+0.02</sup> <sub>-0</sub>	φ99	4	M8	85
A6-140-108	4	φ9	φ14	5	88	φ108	φ16 <sup>+0.02</sup> <sub>-0</sub>	10	47	10	φ16 <sup>+0.02</sup> <sub>-0</sub>	φ108	4	M10	88
A6-150-130	6	φ9	φ14	5	114	φ130	φ16 <sup>+0.02</sup> <sub>-0</sub>	11	46	11	φ16 <sup>+0.02</sup> <sub>-0</sub>	φ130	6	M10	114

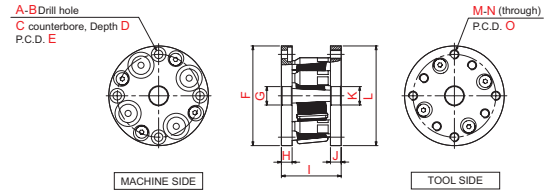

Model	Dimensions [mm]																	
	A	B	C	D	E	F	G	H	I	J	K	L	M	N	O	P	R	Z
LA6-060-060	3	φ5.5	φ9.5	3	48	φ60	φ12 <sup>+0.02</sup> <sub>-0</sub>	7	43	7	4	φ26 <sup>+0</sup> <sub>-0.02</sub>	φ60	3	M6	48	70°	16
LA6-070-065	4	φ5.5	φ9.5	3	54	φ65	φ12 <sup>+0.02</sup> <sub>-0</sub>	7	42.5	7	3.5	φ30 <sup>+0</sup> <sub>-0.02</sub>	φ65	4	M6	54	4°	13
LA6-080-070	4	φ5.5	φ9.5	3	58	φ70	φ12 <sup>+0.02</sup> <sub>-0</sub>	7	42.5	7	3.5	φ30 <sup>+0</sup> <sub>-0.02</sub>	φ70	4	M6	58	2°	-
LA6-090-078	4	φ6.6	φ11	4	65	φ78	φ16 <sup>+0.02</sup> <sub>-0</sub>	8	46.5	8	3.5	φ35 <sup>+0</sup> <sub>-0.02</sub>	φ78	4	M8	65	3°	-
LA6-100-084	4	φ6.6	φ11	4	70	φ84	φ16 <sup>+0.02</sup> <sub>-0</sub>	8	46.5	8	3.5	φ35 <sup>+0</sup> <sub>-0.02</sub>	φ84	4	M8	70	3°	-
LA6-110-088	4	φ6.6	φ11	4	75	φ88	φ16 <sup>+0.02</sup> <sub>-0</sub>	8	48	8	5	φ38 <sup>+0</sup> <sub>-0.02</sub>	φ88	4	M8	75	12°	-
LA6-120-095	4	φ6.6	φ11	4	80	φ95	φ16 <sup>+0.02</sup> <sub>-0</sub>	8	48	8	5	φ45 <sup>+0</sup> <sub>-0.02</sub>	φ95	4	M8	80	5°	-
LA6-130-099	4	φ6.6	φ11	4	85	φ99	φ16 <sup>+0.02</sup> <sub>-0</sub>	8	48	8	5	φ45 <sup>+0</sup> <sub>-0.02</sub>	φ99	4	M8	85	5°	-
LA6-140-108	4	φ9	φ14	5	88	φ108	φ16 <sup>+0.02</sup> <sub>-0</sub>	10	52	10	5	φ45 <sup>+0</sup> <sub>-0.02</sub>	φ108	4	M10	88	-5°	-
LA6-150-130	6	φ9	φ14	5	114	φ130	φ16 <sup>+0.02</sup> <sub>-0</sub>	18	67	18	14	φ55 <sup>+0</sup> <sub>-0.02</sub>	φ130	6	M10	114	57.5°	-

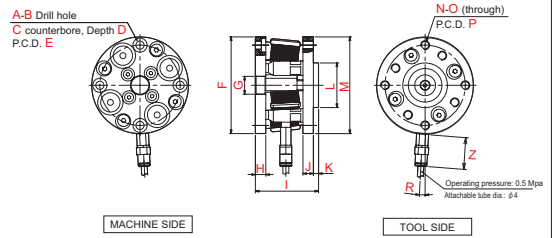

Model	Dimensions [mm]																
	A	B	C	D	E	F	G	H	I	J	K	L	M	N	O	P	Q
S4D-070-065-02																	
S4D-070-065-04	M6	88.5	φ6.6	φ11	4	39.5°	φ102	φ12 <sup>+0.02</sup> <sub>-0</sub>	8	51	φ12 <sup>+0.02</sup> <sub>-0</sub>	φ65	φ76	—	M5	57.5	62°
S4D-070-065-06																	
S4D-090-078-02																	
S4D-090-078-04	M8	104.5	φ9	φ14	5	40.5°	φ121	φ12 <sup>+0.02</sup> <sub>-0</sub>	10	53	φ12 <sup>+0.02</sup> <sub>-0</sub>	φ78	φ89	—	M6	68	-27°
S4D-090-078-06																	
S4D-110-088-03																	
S4D-110-088-06	M8	114.5	φ9	φ14	5	40.5°	φ131	φ12 <sup>+0.02</sup> <sub>-0</sub>	11	54.2	φ12 <sup>+0.02</sup> <sub>-0</sub>	φ88	φ99	—	M8	74	-27°
S4D-110-088-10																	
S4D-140-108-03																	
S4D-140-108-06	M8	134.5	φ9	φ14	5	40.5°	φ151	φ16 <sup>+0.02</sup> <sub>-0</sub>	11	57.55	φ16 <sup>+0.02</sup> <sub>-0</sub>	φ108	φ119	—	M8	91	-27°
S4D-140-108-10																	
S4D-150-130-04																	
S4D-150-130-07	M8	155	φ9	φ14	6	22.5°	φ171	φ16 <sup>+0.02</sup> <sub>-0</sub>	12	59.7	φ16 <sup>+0.02</sup> <sub>-0</sub>	φ130	φ141	—	M8	112	-22.5°
S4D-150-130-12																	

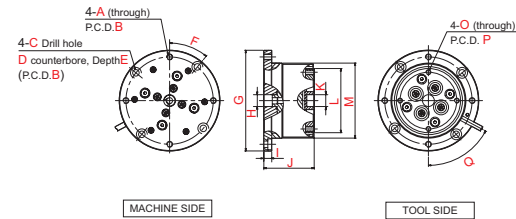

Model	Dimensions [mm]																
	A	B	C	D	E	F	G	H	I	J	K	L	M	N	O	P	Q
SS4D-070-065-02																	
SS4D-070-065-04	M6	57.5	—	—	—	—	φ78	φ12 <sup>+0.02</sup> <sub>-0</sub>	8	51	φ12 <sup>+0.02</sup> <sub>-0</sub>	φ65	φ76	—	M5	57.5	62°
SS4D-070-065-06																	
SS4D-090-078-02																	
SS4D-090-078-04	M8	68	—	—	—	—	φ91	φ12 <sup>+0.02</sup> <sub>-0</sub>	10	53	φ12 <sup>+0.02</sup> <sub>-0</sub>	φ78	φ89	—	M6	68	-27°
SS4D-090-078-06																	
SS4D-110-088-03																	
SS4D-110-088-06	M8	74	—	—	—	—	φ101	φ12 <sup>+0.02</sup> <sub>-0</sub>	11	54.2	φ12 <sup>+0.02</sup> <sub>-0</sub>	φ88	φ99	—	M8	74	-27°
SS4D-110-088-10																	
SS4D-140-108-03																	
SS4D-140-108-06	M8	91	—	—	—	—	φ121	φ16 <sup>+0.02</sup> <sub>-0</sub>	11	57.55	φ16 <sup>+0.02</sup> <sub>-0</sub>	φ108	φ119	—	M8	91	-27°
SS4D-140-108-10																	
SS4D-150-130-04																	
SS4D-150-130-07	M8	112	—	—	—	—	φ143	φ16 <sup>+0.02</sup> <sub>-0</sub>	12	59.7	φ16 <sup>+0.02</sup> <sub>-0</sub>	φ130	φ141	—	M8	112	-22.5°
SS4D-150-130-12																	

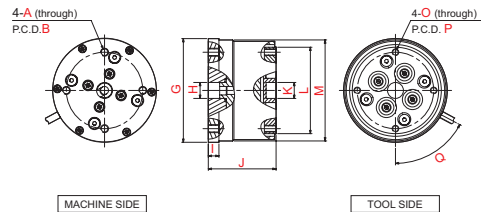

**B Series**  
(press-fitting, flange)



Model	Rated capacity <sup>*1</sup> [N]	Elastic center distance P [mm]	Allowable payload <sup>*1</sup> [N]	Error correction range		Elastic coefficient <sup>*2</sup>			Product weight [kg]	
				Position error [mm]	Torsion error [deg]	Axial direction [N/mm]		Horizontal direction [N/mm]		Torsion error [Nm/rad]
						Compression	Tension			
B6-040-048	6.0	40	14.7	±2	±7.7	625.9	143.2	9.8	2.4	0.6
B6-050-054	7.6	50	19.6	±2	±7.3	1182.1	143.2	11.8	3.0	0.9
B6-060-060	8.5	60	19.6	±2	±6.0	1182.1	143.2	11.8	3.0	1.0
B6-070-065	15.0	70	26.5	±2	±6.6	1575.5	191.3	11.8	4.2	1.1
B6-080-070	25.0	80	26.5	±2	±6.2	1575.5	191.3	11.8	4.2	1.2
B6-090-078	25.0	90	37.3	±2	±5.5	1218.4	225.6	12.8	6.1	1.8
B6-100-084	40.0	100	37.3	±2	±5.0	1218.4	225.6	12.8	6.1	2.0
B6-110-088	40.0	110	38.3	±2	±4.6	1218.4	225.6	12.8	7.0	2.2
B6-120-095	45.0	120	38.3	±2	±5.1	1218.4	225.6	12.8	7.0	2.4
B6-130-099	50.0	130	38.3	±2	±5.1	1218.4	225.6	12.8	7.0	2.6
B6-140-108	55.0	140	78.5	±2	±4.8	1842.3	408.1	14.7	7.7	3.2
B6-150-130	60.0	150	78.5	±2	±4.2	1842.3	408.1	14.7	7.7	4.7

**BS Series**  
(press fit, flangeless type)



Model	Rated capacity <sup>*1</sup> [N]	Elastic center distance P [mm]	Allowable payload <sup>*1</sup> [N]	Error correction range		Elastic coefficient <sup>*2</sup>			Product weight [kg]	
				Position error [mm]	Torsion error [deg]	Axial direction [N/mm]		Horizontal direction [N/mm]		Torsion error [Nm/rad]
						Compression	Tension			
BS6-040-048	6.0	40	14.7	±2	±7.7	625.9	143.2	9.8	2.4	0.5
BS6-050-054	7.6	50	19.6	±2	±7.3	1182.1	143.2	11.8	3.0	0.7
BS6-060-060	8.5	60	19.6	±2	±6.0	1182.1	143.2	11.8	3.0	0.8
BS6-070-065	15.0	70	26.5	±2	±6.6	1575.5	191.3	11.8	4.2	0.9
BS6-080-070	25.0	80	26.5	±2	±6.2	1575.5	191.3	11.8	4.2	1.0
BS6-090-078	25.0	90	37.3	±2	±5.5	1218.4	225.6	12.8	6.1	1.5
BS6-100-084	40.0	100	37.3	±2	±5.0	1218.4	225.6	12.8	6.1	1.6
BS6-110-088	40.0	110	38.3	±2	±4.6	1218.4	225.6	12.8	7.0	1.8
BS6-120-095	45.0	120	38.3	±2	±5.1	1218.4	225.6	12.8	7.0	2.0
BS6-130-099	50.0	130	38.3	±2	±5.1	1218.4	225.6	12.8	7.0	2.1
BS6-140-108	55.0	140	78.5	±2	±4.8	1842.3	408.1	14.7	7.7	2.7
BS6-150-130	60.0	150	78.5	±2	±4.2	1842.3	408.1	14.7	7.7	4.2

**T Series**  
(press fit (rotation prevention), flange type)



Model	Rated capacity <sup>*1</sup> [kN]	Elastic center distance P [mm]	Allowable payload <sup>*1</sup> [N]	Error correction range		Elastic coefficient <sup>*2</sup>			Max. allowable torque [Nm]	Torque reaction [deg]	Product weight [kg]
				Position error [mm]	Torsion error [deg]	Axial direction [N/mm]		Horizontal direction [N/mm]			
						Compression	Tension				
T6-040-048	6.0	40	14.7	±2	0	625.9	143.2	9.8	58.9	±0.3	0.7
T6-050-054	7.6	50	19.6	±2	0	1182.1	143.2	11.8	70.6	±0.3	0.9
T6-060-060	8.5	60	19.6	±2	0	1182.1	143.2	11.8	78.5	±0.2	1.1
T6-070-065	15.0	70	26.5	±2	0	1575.5	191.3	11.8	117.7	±0.2	1.2
T6-080-070	25.0	80	26.5	±2	0	1575.5	191.3	11.8	126.5	±0.2	1.4
T6-090-078	25.0	90	37.3	±2	0	1218.4	225.6	12.8	201.1	±0.2	2.0
T6-100-084	40.0	100	37.3	±2	0	1218.4	225.6	12.8	216.8	±0.15	2.3
T6-110-088	40.0	110	37.8	±2	0	1218.4	225.6	12.8	231.5	±0.15	2.4
T6-120-095	45.0	120	37.8	±2	0	1218.4	225.6	12.8	247.2	±0.1	2.6
T6-130-099	50.0	130	37.8	±2	0	1218.4	225.6	12.8	265.9	±0.1	2.7
T6-140-108	55.0	140	78.0	±2	0	1842.3	408.1	14.7	495.4	±0.1	3.8
T6-150-130	60.0	150	78.0	±2	0	1842.3	408.1	14.7	962.4	±0.1	5.2

**TS Series**  
(press fit (rotation prevention), flangeless type)



Model	Rated capacity <sup>*1</sup> [kN]	Elastic center distance P [mm]	Allowable payload <sup>*1</sup> [N]	Error correction range		Elastic coefficient <sup>*2</sup>			Max. allowable torque [Nm]	Torque reaction [deg]	Product weight [kg]
				Position error [mm]	Torsion error [deg]	Axial direction [N/mm]		Horizontal direction [N/mm]			
						Compression	Tension				
TS6-040-048	6.0	40	14.7	±2	0	625.9	143.2	9.8	58.8	±0.3	0.5
TS6-050-054	7.6	50	19.6	±2	0	1182.1	143.2	11.8	70.6	±0.3	0.7
TS6-060-060	8.5	60	19.6	±2	0	1182.1	143.2	11.8	78.5	±0.2	0.9
TS6-070-065	15.0	70	26.5	±2	0	1575.5	191.3	11.8	117.7	±0.2	1.0
TS6-080-070	25.0	80	26.5	±2	0	1575.5	191.3	11.8	126.5	±0.2	1.1
TS6-090-078	25.0	90	37.3	±2	0	1218.4	225.6	12.8	201.1	±0.2	1.6
TS6-100-084	40.0	100	37.3	±2	0	1218.4	225.6	12.8	216.8	±0.15	1.9
TS6-110-088	40.0	110	37.8	±2	0	1218.4	225.6	12.8	231.5	±0.15	2.0
TS6-120-095	45.0	120	37.8	±2	0	1218.4	225.6	12.8	247.2	±0.1	2.1
TS6-130-099	50.0	130	37.8	±2	0	1218.4	225.6	12.8	265.9	±0.1	2.3
TS6-140-108	55.0	140	78.0	±2	0	1842.3	408.1	14.7	495.4	±0.1	3.3
TS6-150-130	60.0	150	78.0	±2	0	1842.3	408.1	14.7	962.4	±0.1	4.7

\*1 Rated capacity & allowance load: Do contact us if it exceeds the value written in specifications.

\*2 Elastic coefficient: Elasticity at Elastic center (P). It is the average value until stopper inside CenterMaster is activated.

\* CenterMaster corrects max. ±2 mm position error. This value varies depending on size of chamfered surface.

Please avoid using in an environment that will corrode the interior of this product.

Line-up is as of Feb 2023. Contact us for custom orders.

Model	Dimensions [mm]																
	A	B	C	D	E	F	G	H	I	J	K	L	M	N	O	P	Q
B6-040-048	M6	71.5	φ6.6	φ11	3	45°	φ85	φ12 <sup>+0.02</sup> <sub>-0.3</sub>	7	37	φ12 <sup>+0.02</sup> <sub>-0.3</sub>	φ48	φ58	3	M6	36	22.5°
B6-050-054	M6	77.5	φ6.6	φ11	3	45°	φ91	φ12 <sup>+0.02</sup> <sub>-0.3</sub>	7	46	φ12 <sup>+0.02</sup> <sub>-0.3</sub>	φ54	φ64	3	M6	43	22.5°
B6-060-060	M6	83.5	φ6.6	φ11	3	45°	φ97	φ12 <sup>+0.02</sup> <sub>-0.3</sub>	7	46	φ12 <sup>+0.02</sup> <sub>-0.3</sub>	φ60	φ70	3	M6	48	22.5°
B6-070-065	M6	88.5	φ6.6	φ11	3	45°	φ102	φ12 <sup>+0.02</sup> <sub>-0.3</sub>	7	46	φ12 <sup>+0.02</sup> <sub>-0.3</sub>	φ65	φ75	4	M6	54	22.5°
B6-080-070	M6	93.5	φ6.6	φ11	3	45°	φ107	φ12 <sup>+0.02</sup> <sub>-0.3</sub>	7	46	φ12 <sup>+0.02</sup> <sub>-0.3</sub>	φ70	φ80	4	M6	58	22.5°
B6-090-078	M8	104.5	φ9.0	φ14	4	45°	φ121	φ16 <sup>+0.02</sup> <sub>-0.3</sub>	9	52	φ16 <sup>+0.02</sup> <sub>-0.3</sub>	φ78	φ88	4	M8	65	22.5°
B6-100-084	M8	110.5	φ9.0	φ14	4	45°	φ127	φ16 <sup>+0.02</sup> <sub>-0.3</sub>	9	52	φ16 <sup>+0.02</sup> <sub>-0.3</sub>	φ84	φ94	4	M8	70	22.5°
B6-110-088	M8	114.5	φ9.0	φ14	4	45°	φ131	φ16 <sup>+0.02</sup> <sub>-0.3</sub>	9	52	φ16 <sup>+0.02</sup> <sub>-0.3</sub>	φ88	φ98	4	M8	75	22.5°
B6-120-095	M8	121.5	φ9.0	φ14	4	45°	φ138	φ16 <sup>+0.02</sup> <sub>-0.3</sub>	9	52	φ16 <sup>+0.02</sup> <sub>-0.3</sub>	φ95	φ105	4	M8	80	22.5°
B6-130-099	M8	125.5	φ9.0	φ14	4	45°	φ142	φ16 <sup>+0.02</sup> <sub>-0.3</sub>	9	52	φ16 <sup>+0.02</sup> <sub>-0.3</sub>	φ99	φ109	4	M8	86	22.5°
B6-140-108	M8	134.5	φ9.0	φ14	4	45°	φ151	φ16 <sup>+0.02</sup> <sub>-0.3</sub>	9	56	φ16 <sup>+0.02</sup> <sub>-0.3</sub>	φ108	φ118	4	M10	88	22.5°
B6-150-130	M8	155.0	φ9.0	φ14	5	45°	φ171	φ16 <sup>+0.02</sup> <sub>-0.3</sub>	10	56	φ16 <sup>+0.02</sup> <sub>-0.3</sub>	φ130	φ141	6	M10	114	17.5°

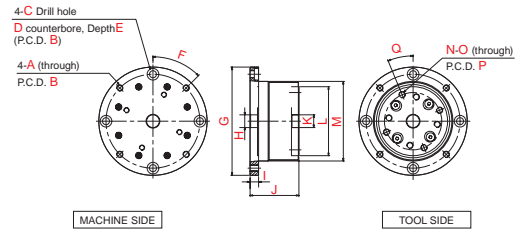

Model	Dimensions [mm]																
	A	B	C	D	E	F	G	H	I	J	K	L	M	N	O	P	Q
BS6-040-048	M6	50					φ60	φ12 <sup>+0.02</sup> <sub>-0.3</sub>	7	37	φ12 <sup>+0.02</sup> <sub>-0.3</sub>	φ48	φ58	3	M6	36	0°
BS6-050-054	M6	58					φ66	φ12 <sup>+0.02</sup> <sub>-0.3</sub>	7	46	φ12 <sup>+0.02</sup> <sub>-0.3</sub>	φ54	φ64	3	M6	43	22.5°
BS6-060-060	M6	62					φ72	φ12 <sup>+0.02</sup> <sub>-0.3</sub>	7	46	φ12 <sup>+0.02</sup> <sub>-0.3</sub>	φ60	φ70	3	M6	48	22.5°
BS6-070-065	M6	67					φ77	φ12 <sup>+0.02</sup> <sub>-0.3</sub>	7	46	φ12 <sup>+0.02</sup> <sub>-0.3</sub>	φ65	φ75	4	M6	54	22.5°
BS6-080-070	M6	72					φ82	φ12 <sup>+0.02</sup> <sub>-0.3</sub>	7	46	φ12 <sup>+0.02</sup> <sub>-0.3</sub>	φ70	φ80	4	M6	58	22.5°
BS6-090-078	M8	78					φ90	φ16 <sup>+0.02</sup> <sub>-0.3</sub>	9	52	φ16 <sup>+0.02</sup> <sub>-0.3</sub>	φ78	φ88	4	M8	65	22.5°
BS6-100-084	M8	84					φ96	φ16 <sup>+0.02</sup> <sub>-0.3</sub>	9	52	φ16 <sup>+0.02</sup> <sub>-0.3</sub>	φ84	φ94	4	M8	70	22.5°
BS6-110-088	M8	88					φ100	φ16 <sup>+0.02</sup> <sub>-0.3</sub>	9	52	φ16 <sup>+0.02</sup> <sub>-0.3</sub>	φ88	φ98	4	M8	75	22.5°
BS6-120-095	M8	95					φ107	φ16 <sup>+0.02</sup> <sub>-0.3</sub>	9	52	φ16 <sup>+0.02</sup> <sub>-0.3</sub>	φ95	φ105	4	M8	80	22.5°
BS6-130-099	M8	99					φ111	φ16 <sup>+0.02</sup> <sub>-0.3</sub>	9	52	φ16 <sup>+0.02</sup> <sub>-0.3</sub>	φ99	φ109	4	M8	86	22.5°
BS6-140-108	M8	108					φ120	φ16 <sup>+0.02</sup> <sub>-0.3</sub>	9	56	φ16 <sup>+0.02</sup> <sub>-0.3</sub>	φ108	φ118	4	M10	88	22.5°
BS6-150-130	M8	130					φ143	φ16 <sup>+0.02</sup> <sub>-0.3</sub>	10	56	φ16 <sup>+0.02</sup> <sub>-0.3</sub>	φ130	φ141	6	M10	114	-7.5°

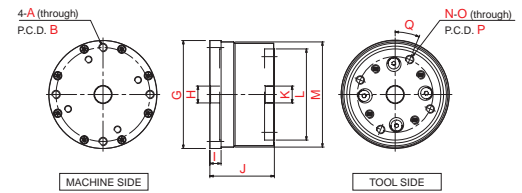

Model	Dimensions [mm]																
	A	B	C	D	E	F	G	H	I	J	K	L	M	N	O	P	Q
T6-040-048	M6	71.5	φ6.6	φ11	3	45°	φ85	φ12 <sup>+0.02</sup> <sub>-0.3</sub>	7	37	φ12 <sup>+0.02</sup> <sub>-0.3</sub>	φ48	φ58	3	M6	36	22.5°
T6-050-054	M6	77.5	φ6.6	φ11	3	45°	φ91	φ12 <sup>+0.02</sup> <sub>-0.3</sub>	7	46	φ12 <sup>+0.02</sup> <sub>-0.3</sub>	φ54	φ64	3	M6	43	22.5°
T6-060-060	M6	83.5	φ6.6	φ11	3	45°	φ97	φ12 <sup>+0.02</sup> <sub>-0.3</sub>	7	46	φ12 <sup>+0.02</sup> <sub>-0.3</sub>	φ60	φ70	3	M6	48	22.5°
T6-070-065	M6	88.5	φ6.6	φ11	3	45°	φ102	φ12 <sup>+0.02</sup> <sub>-0.3</sub>	7	46	φ12 <sup>+0.02</sup> <sub>-0.3</sub>	φ65	φ75	4	M6	54	22.5°
T6-080-070	M6	93.5	φ6.6	φ11	3	45°	φ107	φ12 <sup>+0.02</sup> <sub>-0.3</sub>	7	46	φ12 <sup>+0.02</sup> <sub>-0.3</sub>	φ70	φ80	4	M6	58	22.5°
T6-090-078	M8	104.5	φ9.0	φ14	4	45°	φ121	φ16 <sup>+0.02</sup> <sub>-0.3</sub>	9	52	φ16 <sup>+0.02</sup> <sub>-0.3</sub>	φ78	φ88	4	M8	65	22.5°
T6-100-084	M8	110.5	φ9.0	φ14	4	45°	φ127	φ16 <sup>+0.02</sup> <sub>-0.3</sub>	9	52	φ16 <sup>+0.02</sup> <sub>-0.3</sub>	φ84	φ94	4	M8	70	22.5°
T6-110-088	M8	114.5	φ9.0	φ14	4	45°	φ131	φ16 <sup>+0.02</sup> <sub>-0.3</sub>	9	52	φ16 <sup>+0.02</sup> <sub>-0.3</sub>	φ88	φ98	4	M8	75	22.5°
T6-120-095	M8	121.5	φ9.0	φ14	4	45°	φ138	φ16 <sup>+0.02</sup> <sub>-0.3</sub>	9	52	φ16 <sup>+0.02</sup> <sub>-0.3</sub>	φ95	φ105	4	M8	80	22.5°
T6-130-099	M8	125.5	φ9.0	φ14	4	45°	φ142	φ16 <sup>+0.02</sup> <sub>-0.3</sub>	9	52	φ16 <sup>+0.02</sup> <sub>-0.3</sub>	φ99	φ109	4	M8	86	22.5°
T6-140-108	M8	134.5	φ9.0	φ14	4	45°	φ151	φ16 <sup>+0.02</sup> <sub>-0.3</sub>	9	56	φ16 <sup>+0.02</sup> <sub>-0.3</sub>	φ108	φ118	4	M10	88	22.5°
T6-150-130	M8	155.0	φ9.0	φ14	5	45°	φ171	φ16 <sup>+0.02</sup> <sub>-0.3</sub>	10	56	φ16 <sup>+0.02</sup> <sub>-0.3</sub>	φ130	φ141	6	M10	114	17.5°

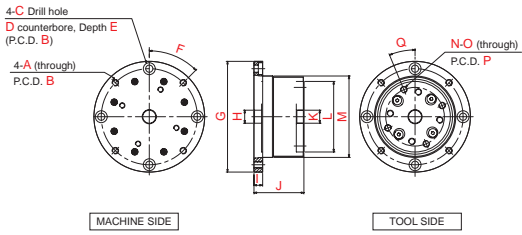

Model	Dimensions [mm]																
	A	B	C	D	E	F	G	H	I	J	K	L	M	N	O	P	Q
TS6-040-048	M6	50					φ60	φ12 <sup>+0.02</sup> <sub>-0.3</sub>	7	37	φ12 <sup>+0.02</sup> <sub>-0.3</sub>	φ48	φ58	3	M6	36	0°
TS6-050-054	M6	58					φ66	φ12 <sup>+0.02</sup> <sub>-0.3</sub>	7	46	φ12 <sup>+0.02</sup> <sub>-0.3</sub>	φ54	φ64	3	M6	43	22.5°
TS6-060-060	M6	62					φ72	φ12 <sup>+0.02</sup> <sub>-0.3</sub>	7	46	φ12 <sup>+0.02</sup> <sub>-0.3</sub>	φ60	φ70	3	M6	48	22.5°
TS6-070-065	M6	67					φ77	φ12 <sup>+0.02</sup> <sub>-0.3</sub>	7	46	φ12 <sup>+0.02</sup> <sub>-0.3</sub>	φ65	φ75	4	M6	54	22.5°
TS6-080-070	M6	72					φ82	φ12 <sup>+0.02</sup> <sub>-0.3</sub>	7	46	φ12 <sup>+0.02</sup> <sub>-0.3</sub>	φ70	φ80	4	M6	58	22.5°
TS6-090-078	M8	78					φ90	φ16 <sup>+0.02</sup> <sub>-0.3</sub>	9	52	φ16 <sup>+0.02</sup> <sub>-0.3</sub>	φ78	φ88	4	M8	65	22.5°
TS6-100-084	M8	84					φ96	φ16 <sup>+0.02</sup> <sub>-0.3</sub>	9	52	φ16 <sup>+0.02</sup> <sub>-0.3</sub>	φ84	φ94	4	M8	70	22.5°
TS6-110-088	M8	88					φ100	φ16 <sup>+0.02</sup> <sub>-0.3</sub>	9	52	φ16 <sup>+0.02</sup> <sub>-0.3</sub>	φ88	φ98	4	M8	75	22.5°
TS6-120-095	M8	95					φ107	φ16 <sup>+0.02</sup> <sub>-0.3</sub>	9	52	φ16 <sup>+0.02</sup> <sub>-0.3</sub>	φ95	φ105	4	M8	80	22.5°
TS6-130-099	M8	99					φ111	φ16 <sup>+0.02</sup> <sub>-0.3</sub>	9	52	φ16 <sup>+0.02</sup> <sub>-0.3</sub>	φ99	φ109	4	M8	86	22.5°
TS6-140-108	M8	108					φ120	φ16 <sup>+0.02</sup> <sub>-0.3</sub>	9	56	φ16 <sup>+0.02</sup> <sub>-0.3</sub>	φ108	φ118	4	M10	88	22.5°
TS6-150-130	M8	130					φ143	φ16 <sup>+0.02</sup> <sub>-0.3</sub>	10	56	φ16 <sup>+0.02</sup> <sub>-0.3</sub>	φ130	φ141	6	M10	114	-7.5°

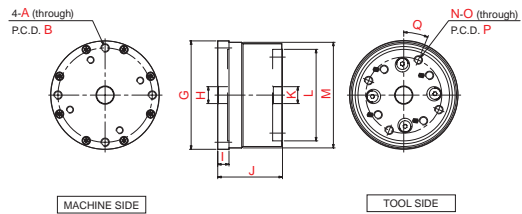



**BH Series**  
(press fit horizontally, flange type)



Model	Rated capacity <sup>*1</sup> [N]	Elastic center distance P [mm]	Allowable payload <sup>*1</sup> [N]	Error correction range		Elastic coefficient <sup>*2</sup>				Product weight [kg]
				Position error [mm]	Torsion error [deg]	Axial direction [N/mm]		Horizontal direction [N/mm]	Torsion error [Nm/rad]	
						Compression	Tension			
BH6-040-048	6.0	40	14.7	±2	±7.7	625.9	143.2	9.8	2.4	1.0
BH6-050-054	7.6	50	19.6	±2	±7.3	1182.1	143.2	11.8	3.0	1.3
BH6-060-060	8.5	60	19.6	±2	±6.0	1182.1	143.2	11.8	3.0	1.5
BH6-070-065	15.0	70	26.5	±2	±6.6	1575.5	191.3	11.8	4.2	1.8
BH6-080-070	25.0	80	26.5	±2	±6.2	1575.5	191.3	11.8	4.2	2.0
BH6-090-078	25.0	90	37.3	±2	±5.5	1218.4	225.6	12.8	6.1	2.5
BH6-100-084	40.0	100	37.3	±2	±5.0	1218.4	225.6	12.8	6.1	2.8
BH6-110-088	40.0	110	38.3	±2	±4.6	1218.4	225.6	12.8	7.0	3.5
BH6-120-095	45.0	120	38.3	±2	±5.1	1218.4	225.6	12.8	7.0	3.8
BH6-130-099	50.0	130	38.3	±2	±5.1	1218.4	225.6	12.8	7.0	4.0
BH6-140-108	55.0	140	78.5	±2	±4.8	1842.3	408.1	14.7	7.7	5.0
BH6-150-130	60.0	150	78.5	±2	±4.2	1842.3	408.1	14.7	7.7	6.5

Model	Dimensions [mm]																							
	A	B	C	D	E	F	G	H	I	J	K	L	M	N	O	P	Q	R	S	T	U	V	W	X
BH6-040-048	M6	71.5	φ6.6	φ11	3	45°	φ85	φ12 <sup>+0.02/-0</sup>	7	37	φ12 <sup>+0.02/-0</sup>	φ48	φ58	3	M6	36	22.5°	45	50	22.5°	M5	0.5	2.0	15x43x6
BH6-050-054	M6	77.5	φ6.6	φ11	3	45°	φ91	φ12 <sup>+0.02/-0</sup>	7	46	φ12 <sup>+0.02/-0</sup>	φ54	φ64	3	M6	43	22.5°	55	60	22.5°	M5	0.5	2.0	15x53x6
BH6-060-060	M6	83.5	φ6.6	φ11	3	45°	φ97	φ12 <sup>+0.02/-0</sup>	7	46	φ12 <sup>+0.02/-0</sup>	φ60	φ70	3	M6	48	22.5°	60	65	22.5°	M5	0.5	2.0	17x58x7
BH6-070-065	M6	88.5	φ6.6	φ11	3	45°	φ102	φ12 <sup>+0.02/-0</sup>	7	46	φ12 <sup>+0.02/-0</sup>	φ65	φ75	4	M6	54	22.5°	70	75	22.5°	M6	0.8	3.0	17x68x7
BH6-080-070	M6	93.5	φ6.6	φ11	3	45°	φ107	φ12 <sup>+0.02/-0</sup>	7	46	φ12 <sup>+0.02/-0</sup>	φ70	φ80	4	M6	58	22.5°	80	85	22.5°	M6	0.8	3.0	17x78x7
BH6-090-078	M8	104.5	φ9.0	φ14	4	45°	φ121	φ16 <sup>+0.02/-0</sup>	9	52	φ16 <sup>+0.02/-0</sup>	φ78	φ88	4	M8	65	22.5°	90	95	22.5°	M6	0.8	3.0	20x86x8
BH6-100-084	M8	110.5	φ9.0	φ14	4	45°	φ127	φ16 <sup>+0.02/-0</sup>	9	52	φ16 <sup>+0.02/-0</sup>	φ84	φ94	4	M8	70	22.5°	100	105	22.5°	M6	0.8	3.0	22x96x8
BH6-110-088	M8	114.5	φ9.0	φ14	4	45°	φ131	φ16 <sup>+0.02/-0</sup>	9	52	φ16 <sup>+0.02/-0</sup>	φ88	φ98	4	M8	75	22.5°	110	120	22.5°	M8	3.6	4.2	22x111x10
BH6-120-095	M8	121.5	φ9.0	φ14	4	45°	φ138	φ16 <sup>+0.02/-0</sup>	9	52	φ16 <sup>+0.02/-0</sup>	φ95	φ105	4	M8	80	22.5°	120	130	22.5°	M8	3.6	4.2	25x121x10
BH6-130-099	M8	125.5	φ9.0	φ14	4	45°	φ142	φ16 <sup>+0.02/-0</sup>	9	52	φ16 <sup>+0.02/-0</sup>	φ99	φ109	4	M8	86	22.5°	130	140	22.5°	M8	3.6	4.2	25x131x10
BH6-140-108	M8	134.5	φ9.0	φ14	4	45°	φ151	φ16 <sup>+0.02/-0</sup>	9	56	φ16 <sup>+0.02/-0</sup>	φ108	φ118	4	M10	88	22.5°	140	150	22.5°	M10	1.6	6.3	28x141x14
BH6-150-130	M8	155.0	φ9.0	φ14	5	45°	φ171	φ16 <sup>+0.02/-0</sup>	10	56	φ16 <sup>+0.02/-0</sup>	φ130	φ141	6	M10	114	17.5°	150	160	22.5°	M10	1.6	6.3	28x150x12

**TH Series**  
(press fit horizontally, rotation prevention, flange type)



Model	Rated capacity <sup>*1</sup> [kN]	Elastic center distance P [mm]	Allowable payload <sup>*1</sup> [N]	Error correction range		Elastic coefficient <sup>*2</sup>				Max. allowable torque [Nm]	Torque reaction [deg]	Product weight [kg]
				Position error [mm]	Torsion error [deg]	Axial direction [N/mm]		Horizontal direction [N/mm]				
						Compression	Tension					
TH6-040-048	6.0	40	14.7	±2	0	625.9	143.2	9.8	58.9	±0.3	1.1	
TH6-050-054	7.6	50	19.6	±2	0	1182.1	143.2	11.8	70.6	±0.3	1.3	
TH6-060-060	8.5	60	19.6	±2	0	1182.1	143.2	11.8	78.5	±0.2	1.6	
TH6-070-065	15.0	70	26.5	±2	0	1575.5	191.3	11.8	117.7	±0.2	1.9	
TH6-080-070	25.0	80	26.5	±2	0	1575.5	191.3	11.8	126.5	±0.2	2.2	
TH6-090-078	25.0	90	37.3	±2	0	1218.4	225.6	12.8	201.1	±0.2	2.7	
TH6-100-084	40.0	100	37.3	±2	0	1218.4	225.6	12.8	216.8	±0.15	3.1	
TH6-110-088	40.0	110	37.8	±2	0	1218.4	225.6	12.8	231.5	±0.15	3.7	
TH6-120-095	45.0	120	37.8	±2	0	1218.4	225.6	12.8	247.2	±0.1	4.0	
TH6-130-099	50.0	130	37.8	±2	0	1218.4	225.6	12.8	265.9	±0.1	4.1	
TH6-140-108	55.0	140	78.0	±2	0	1842.3	408.1	14.7	495.4	±0.1	5.6	
TH6-150-130	60.0	150	78.0	±2	0	1842.3	408.1	14.7	962.4	±0.1	7.0	

Model	Dimensions [mm]																							
	A	B	C	D	E	F	G	H	I	J	K	L	M	N	O	P	Q	R	S	T	U	V	W	X
TH6-040-048	M6	71.5	φ6.6	φ11	3	45°	φ85	φ12 <sup>+0.02/-0</sup>	7	37	φ12 <sup>+0.02/-0</sup>	φ48	φ58	3	M6	36	22.5°	45	50	22.5°	M5	0.5	2.0	15x43x6
TH6-050-054	M6	77.5	φ6.6	φ11	3	45°	φ91	φ12 <sup>+0.02/-0</sup>	7	46	φ12 <sup>+0.02/-0</sup>	φ54	φ64	3	M6	43	22.5°	55	60	22.5°	M5	0.5	2.0	15x53x6
TH6-060-060	M6	83.5	φ6.6	φ11	3	45°	φ97	φ12 <sup>+0.02/-0</sup>	7	46	φ12 <sup>+0.02/-0</sup>	φ60	φ70	3	M6	48	22.5°	60	65	22.5°	M5	0.5	2.0	17x58x7
TH6-070-065	M6	88.5	φ6.6	φ11	3	45°	φ102	φ12 <sup>+0.02/-0</sup>	7	46	φ12 <sup>+0.02/-0</sup>	φ65	φ75	4	M6	54	22.5°	70	75	22.5°	M6	0.8	3.0	17x68x7
TH6-080-070	M6	93.5	φ6.6	φ11	3	45°	φ107	φ12 <sup>+0.02/-0</sup>	7	46	φ12 <sup>+0.02/-0</sup>	φ70	φ80	4	M6	58	22.5°	80	85	22.5°	M6	0.8	3.0	17x78x7
TH6-090-078	M8	104.5	φ9.0	φ14	4	45°	φ121	φ16 <sup>+0.02/-0</sup>	9	52	φ16 <sup>+0.02/-0</sup>	φ78	φ88	4	M8	65	22.5°	90	95	22.5°	M6	0.8	3.0	20x86x8
TH6-100-084	M8	110.5	φ9.0	φ14	4	45°	φ127	φ16 <sup>+0.02/-0</sup>	9	52	φ16 <sup>+0.02/-0</sup>	φ84	φ94	4	M8	70	22.5°	100	105	22.5°	M6	0.8	3.0	22x96x8
TH6-110-088	M8	114.5	φ9.0	φ14	4	45°	φ131	φ16 <sup>+0.02/-0</sup>	9	52	φ16 <sup>+0.02/-0</sup>	φ88	φ98	4	M8	75	22.5°	110	120	22.5°	M8	3.6	4.2	22x111x10
TH6-120-095	M8	121.5	φ9.0	φ14	4	45°	φ138	φ16 <sup>+0.02/-0</sup>	9	52	φ16 <sup>+0.02/-0</sup>	φ95	φ105	4	M8	80	22.5°	120	130	22.5°	M8	3.6	4.2	25x121x10
TH6-130-099	M8	125.5	φ9.0	φ14	4	45°	φ142	φ16 <sup>+0.02/-0</sup>	9	52	φ16 <sup>+0.02/-0</sup>	φ99	φ109	4	M8	86	22.5°	130	140	22.5°	M8	3.6	4.2	25x131x10
TH6-140-108	M8	134.5	φ9.0	φ14	4	45°	φ151	φ16 <sup>+0.02/-0</sup>	9	56	φ16 <sup>+0.02/-0</sup>	φ108	φ118	4	M10	88	22.5°	140	150	22.5°	M10	1.6	6.3	28x141x14
TH6-150-130	M8	155.0	φ9.0	φ14	5	45°	φ171	φ16 <sup>+0.02/-0</sup>	10	56	φ16 <sup>+0.02/-0</sup>	φ130	φ141	6	M10	114	17.5°	150	160	22.5°	M10	1.6	6.3	28x150x12

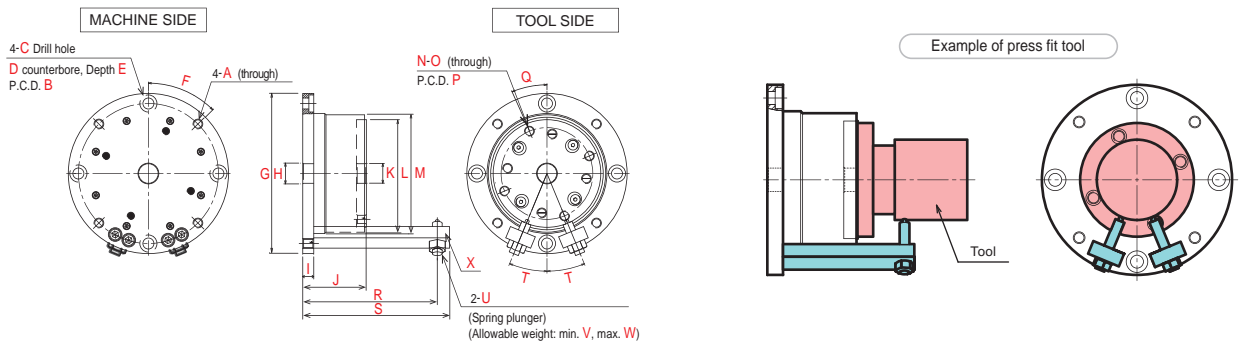

\*1 Rated capacity & allowance load: Do contact us if it exceeds the value written in specifications.  
 \*2 Elastic coefficient: Elasticity at Elastic center (P). It is the average value until stopper inside CenterMaster is activated.  
 \* CenterMaster corrects max. ±2 mm position error. This value varies depending on size of chamfered surface.

Please avoid using in an environment that will corrode the interior of this product.

Line-up is as of Feb 2023. Contact us for custom orders.

## S and SS series - Load cell specifications

Rated capacity	Refer to mechanical specifications on the data sheet enclosed with the product
Rated output	Refer to electrical specifications on the data sheet enclosed with the product
Non-linearity	1% R.O.
Hysteresis	0.5% R.O.
Repeatability	0.5% R.O.
Creep	0.5% R.O./min.
Zero balance	±1% R.O.
Compensated temperature range	0 to +40°C
Operation temperature range	0 to +70°C
Temperature effect on zero	±0.1% R.O./10°C
Temperature effect on span	±0.1% R.O./10°C
Input resistance	700±10
Output resistance	700±10
Insulation resistance	10 V
Excitation voltage capacity	15 V
Insulation resistance (DC 50 V)	2000 M or more
Max. safe overload	150% R.C.
Max. marginal overload	200% R.C.
Cable length (4-conductor color shield)	Approx. 5 m

### ● Wiring diagram

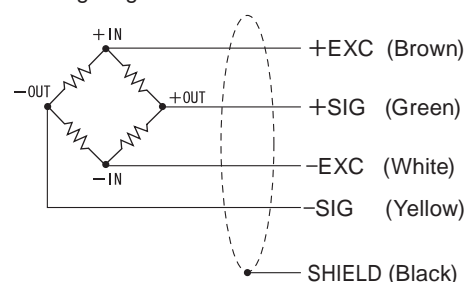

### ● 4 conductor shield cable Approx. 5 m

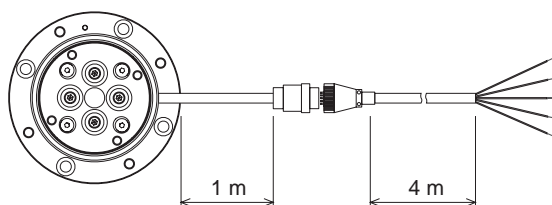

## Structure of product code

Model: XXXX - YYY - ZZZ - WW

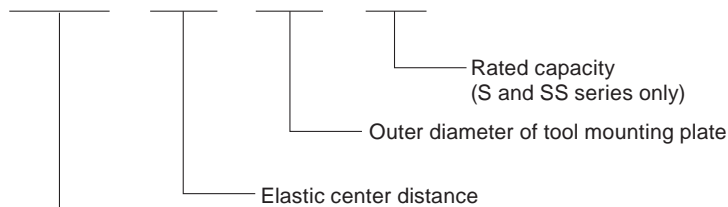

- A\*--: For insertion
- LA\*-: For insertion (Airlock type)
- S\*\*--: For press-fitting (Integrated load cell, with flange)
- SS\*\*--: For press-fitting (Integrated load cell, without flange)
- B\*--: For press-fitting (with flange)
- BS\*--: For press-fitting (without flange)
- T\*--: For press-fitting (Rotation prevention, with flange)
- TS\*--: For press-fitting (Rotation prevention, without flange)
- BH\*--: For Press fit horizontally (with flange)
- TH\*--: For Press fit horizontally (Rotation prevention, with flange)

- Determine (d<D) for insertion and (d>D) for press-fitting
- Check the allowable weight of assembly (press-fit) tool
- Check the maximum applied pressure, in case of press-fitting
- Check the elastic center distance
- Check the error correction range

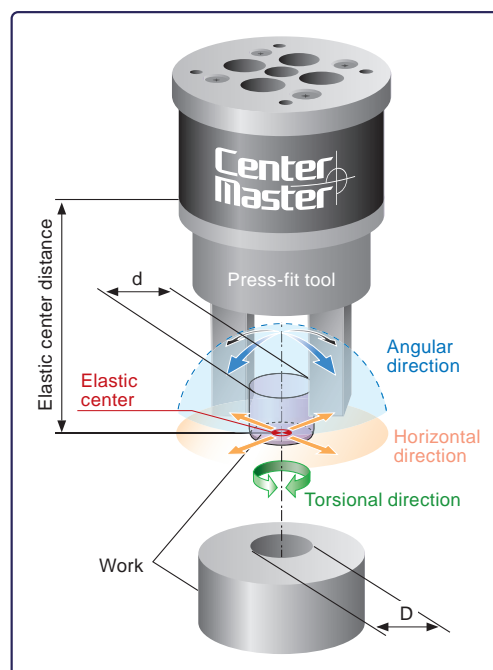

Elastic center distance

In general, an error range within ± 5 mm for the elastic center distance is recommended. The correction function of the center error may weaken if the error range is large.

Allowable weight for assembly (press-fit) tool

The maximum value that can be used by mounting to the center master with the combined value of weights of the press-fit tool and the work. When exceeded, the correction function of center error may not operate and the life may be significantly reduced.

Outer diameter of tool mounting plate

Set the outer diameter of the work at 90% or less than the outer diameter of the mounting plate. The correction function of the center error may weaken if the outer diameter of the work is large.