

PW15AH SINGLE POINT TYPE LOAD CELL

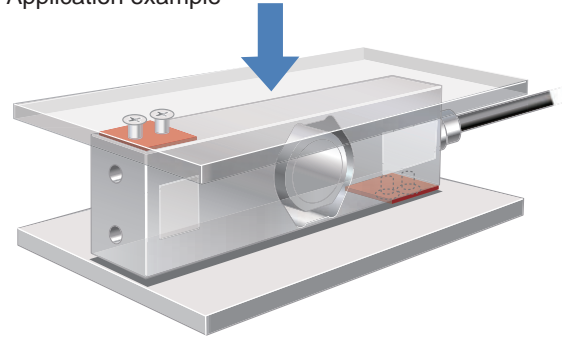

● Application example



Specifications

Model	PW15AH-10KG, PW15AH-20KG, PW15AH-50KG, PW15AH-100KG
Rated capacity	10 kg, 20 kg, 50 kg, 100 kg
Rated output	2.0±0.2 mV/V
Safe overload	150% R.C.
Maximum safe side overload	300% R.C.
Zero balance	0±0.1 mV/V
Non-linearity	0.0166% R.O. typ.
Hysteresis	0.0166% R.O. typ.
Compensated temperature range	-10 to +40°C
Safe temperature range	-10 to +50°C
Temperature effect on zero	0.0140% R.O./10°C
Temperature effect on span	0.0175% R.O./10°C (+20 to +40°C), 0.0117% R.O./10°C (-10 to +20°C)
Input resistance	300 to 500
Output resistance	300 to 500
Recommended excitation voltage	1 to 12 V
Insulation resistance	1000 M or more
Degrees of protection	IP68
Cable	6-conductor shield cable 3 m, Cable end: 7 wires
Load cell material	Stainless steel

● Wiring diagram

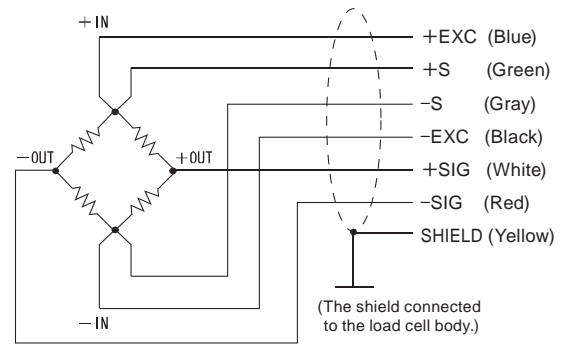

External dimension

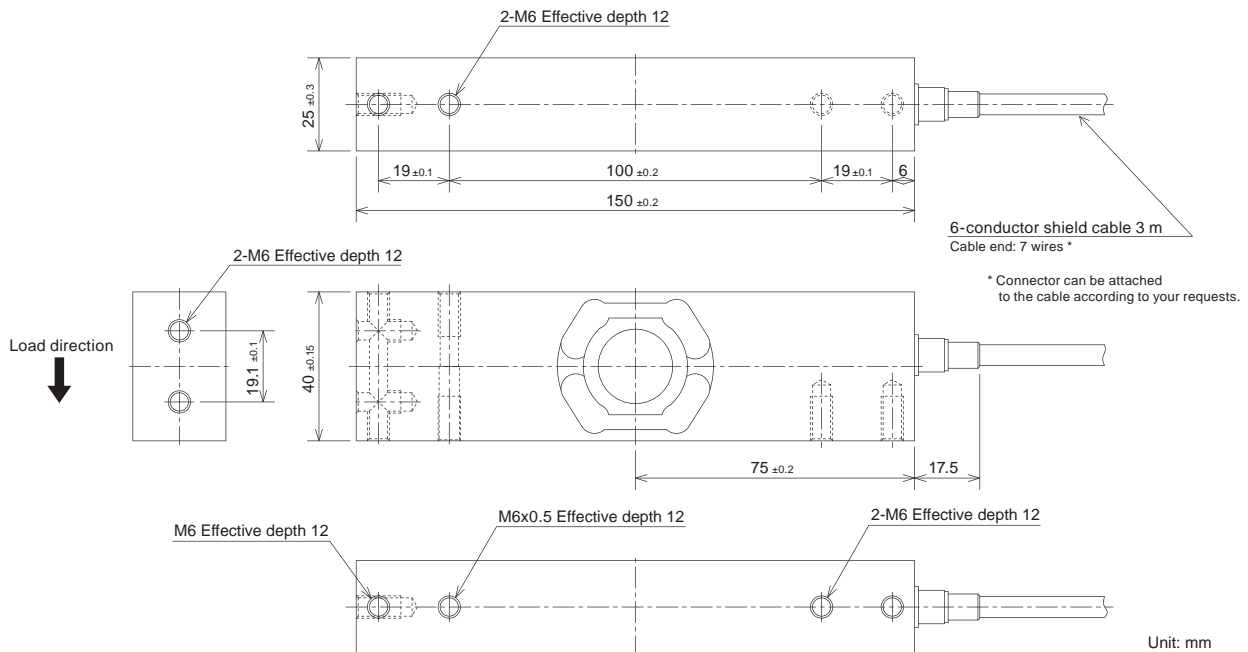

Unit: mm

Model	Deflection at rated	Natural frequency	Maximum off center distance	Maximum platform size	Weight
PW15AH-10KG	0.5 mm or less	169 Hz	160 mm	500×400 mm	1.0 kg
PW15AH-20KG		232 Hz			
PW15AH-50KG		352 Hz			
PW15AH-100KG		492 Hz			