

PW27AP

HYGIENIC SINGLE POINT TYPE
LOAD CELL



IP69K

Completely waterproof,
all stainless steel-made &
hermetically sealed structure
Hygienic load cell designed
for food production

Detachable cable

Specifications

Model	PW27AP-10KG	PW27AP-20KG
Rated capacity	10 kg	20 kg
Rated output	2.0±0.2 mV/V	
Limit load at 20 mm eccentricity	1000% R.C.	
Service load at max. 120 mm eccentricity	150% R.C.	
Maximum safe side overload	200% R.C.	
Zero balance	0±0.1 mV/V	
Non-linearity	0.0166% R.O. typ.	
Hysteresis	0.0166% R.O. typ.	
Compensated temperature range	-10 to +40°C	
Safe temperature range	-10 to +70°C	
Temperature effect on zero	0.0140% R.O./10°C	
Temperature effect on span	0.0175% R.O./10°C (+20 to +40°C) 0.0117% R.O./10°C (-10 to +20°C)	
Input resistance	300 to 500	
Output resistance	300 to 500	
Recommended excitation voltage	1 to 12 V	
Insulation resistance	1000 M or more	
Degrees of protection	IP68, IP69K*	
Loadcell material	Stainless steel	
Cleaning temperature	Up to 120°C in 10 minutes	

* IP69K load condition: DIN 40050 part 9 compliant

Application example

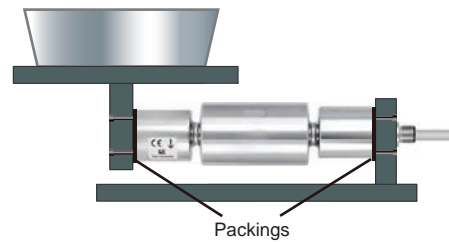

Wiring diagram

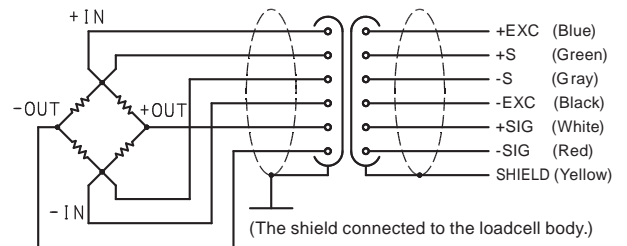

External dimension

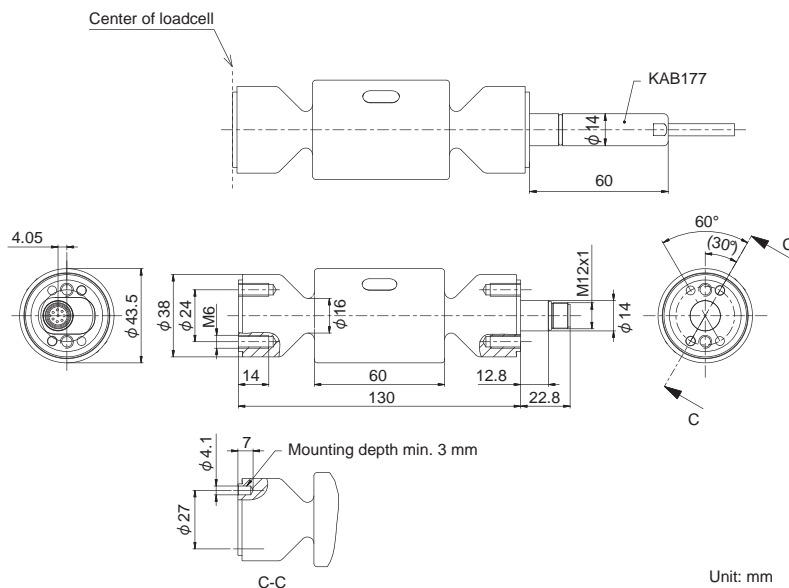

Optional accessories

KAB177-3



φ5.4 6-conductor hygiene design cable 3 m
Cable end: 7 wires

Model	Deflection at rated	Natural frequency	Maximum platform size	Weight
PW27AP-10KG	0.19 mm	210 Hz	400x400 mm	0.8 kg
PW27AP-20KG	0.18 mm	315 Hz		