

# B412 JUNCTION BOX



**IP65**

- Up to 4 units of load cells can be connected in parallel
- Made of stainless steel
- Dust & drip proof type (IP65 equivalent)

## Specifications

Clamp for cable fixation	Connection with load cell (four): Acceptable cable diameter 5 to 10 φ Connection with indicator (one): Acceptable cable diameter 6 to 12 φ
Number of connectable load cells	1 to 4 units
Operation condition	Operation temperature range: -20 to +60°C Storage temperature range: -40 to +80°C
Degrees of protection	IP65 equivalent
Weight	Approx. 1.3 kg
Attachments	Mini driver.....1      Waterproof stick.....4 Silica gel.....1      (Factory-installed) Operation manual.....1

## External dimension

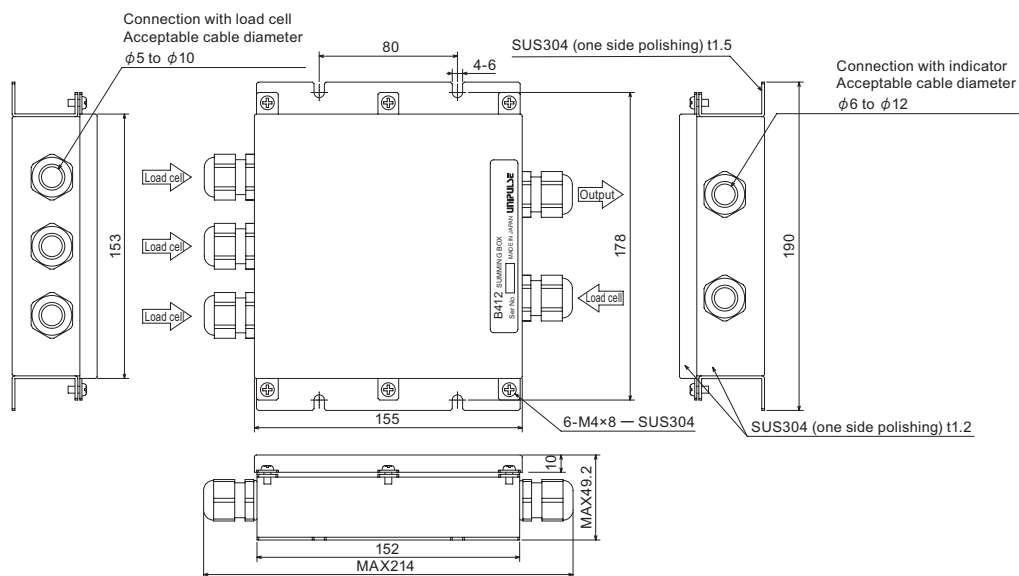

Unit: mm