



HIGH STIFFNESS / HIGH RESPONSE TYPE LOAD CELL



Flexible cable

"Hardly breakable!" - Load cell with an innovative concept!
A strain gauge sensor with phenomenal stiffness and responsiveness.

Robust

Amazing stiffness is achieved with a strain gauge!
Suitable for applications requiring extra-low deformation during force measurements, such as measuring of grinding or machining forces.

High responsiveness

High resonant frequency is possible with strain gauge type sensor!
It can be used to monitor a high-speed phenomenon.

Safe overload of 500%

Overload up to 500% of the rated capacity does not affect the accuracy.
Stable measurement can be performed for a long term even in sever loading conditions (e.g. press fitting machines).

Example of use

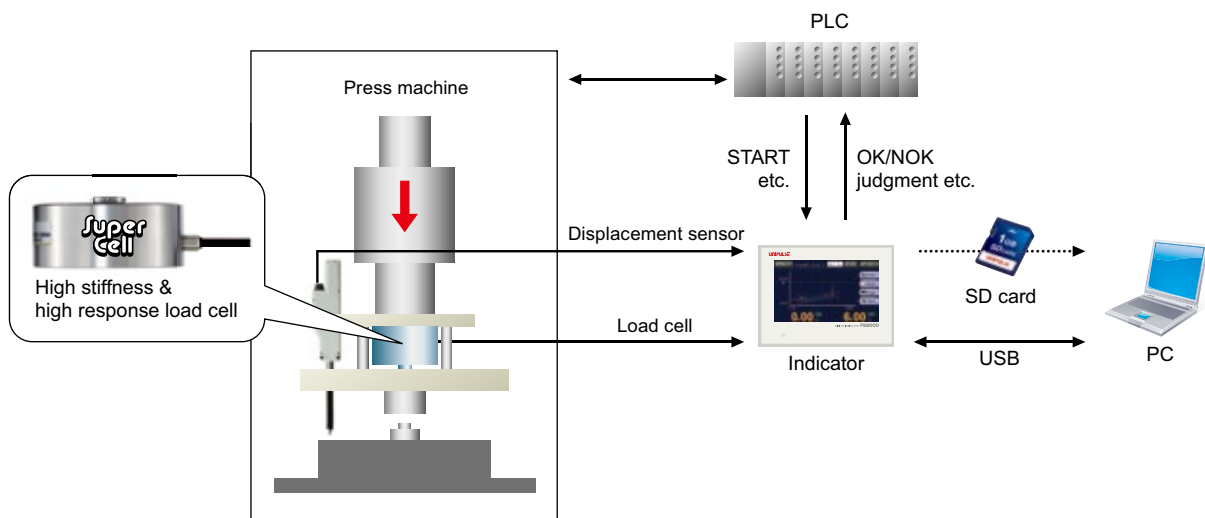

Specifications

Model	SCB-□N										
	□ : Rated capacity										
Rated capacity	100 N	200 N	500 N	1 kN	2 kN	5 kN	10 kN	20 kN	50 kN	100 kN	200 kN
Rated output	0.4 mV/V±0.2%			0.4 mV/V±0.1%							
Safe overload	500% R.C.										
Zero balance	±1% R.O.*1			±0.3% R.O.							
Non-linearity	0.2 or less R.O.										
Hysteresis	0.2 or less R.O.										
Repeatability	0.1 or less R.O.										
Compensated temperature range	- 10 to +60°C										
Safe temperature range	- 20 to +70°C										
Temperature effect on zero	0.015% R.O./°C or below										
Temperature effect on span	0.01% R.O./°C or below										
Input resistance	Approx. 700 Ω			Approx. 1000 Ω							
Output resistance	Approx. 700 Ω			Approx. 1000 Ω							
Recommended excitation voltage	5 V			10 V							
Maximum excitation voltage	7.5 V			15 V							
Insulation resistance (DC 50 V)	1000 MΩ or more										
Cable	φ2.5 6-conductor flexible cable 3 m, Cable end: 7 wires			φ5 6-conductor flexible cable 3 m, Cable end: 7 wires			φ7 6-conductor flexible cable 3 m, Cable end: 7 wires				
Load cell material	Stainless steel										
RoHS directives	2011/65/EU (EU)2015/863										

*1 Specification changed.

● Wiring diagram

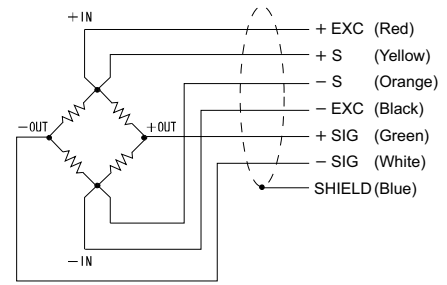

External dimension

■ SCB-100N/200N/500N

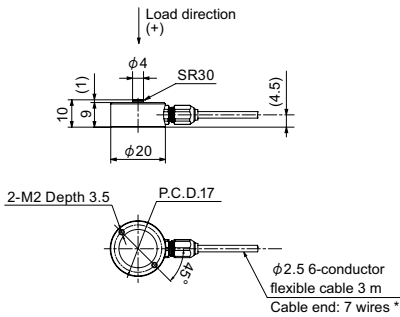

■ SCB-1kN/2kN/5kN

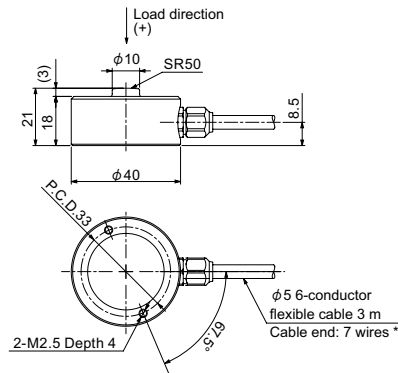

■ SCB-10kN/20kN

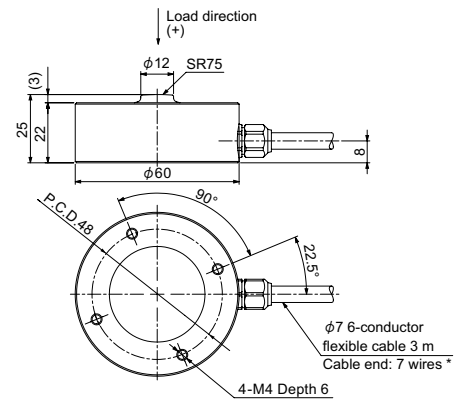

■ SCB-50kN

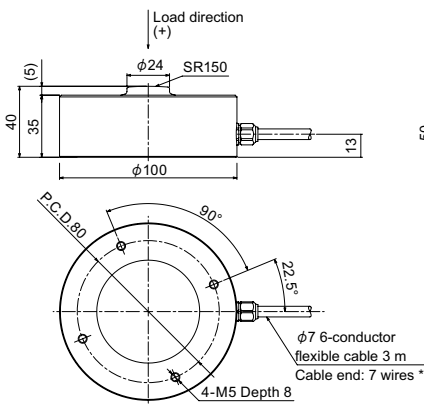

■ SCB-100kN

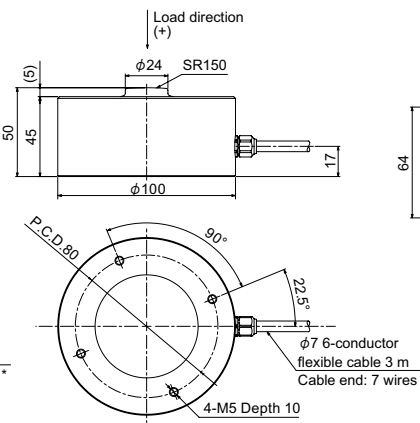

■ SCB-200kN

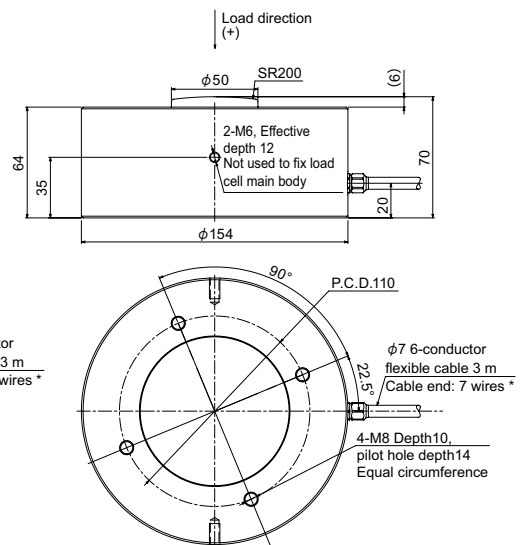

Model	Deflection at rated capacity	Natural frequency	Weight
SCB-100N	0.015 mm	40 kHz	20 g
SCB-200N	0.015 mm	40 kHz	20 g
SCB-500N	0.015 mm	40 kHz	20 g
SCB-1kN	0.015 mm	26 kHz	130 g
SCB-2kN	0.020 mm	26 kHz	130 g
SCB-5kN	0.025 mm	26 kHz	130 g
SCB-10kN	0.025 mm	26 kHz	400 g
SCB-20kN	0.035 mm	26 kHz	400 g
SCB-50kN	0.065 mm	15 kHz	2.0 kg
SCB-100kN	0.100 mm	15 kHz	2.3 kg
SCB-200kN	0.100 mm	8 kHz	8.2 kg

* Connector can be attached to the cable according to your requests.
Refer to 84 pages for details.

Unit: mm