

UNGS COMPRESSION TYPE LOAD CELL



Flexible cable

Specifications

Model	UNGS-1KN, UNGS-2KN, UNGS-5KN, UNGS-10KN, UNGS-20KN
Rated capacity	1 kN, 2 kN, 5 kN, 10 kN, 20 kN
Rated output	2 mV/V \pm 1%
Safe overload	150% R.C.
Zero balance	\pm 5% R.O.
Non-linearity	0.15% or less R.O.
Hysteresis	0.1% or less R.O.
Repeatability	0.1% or less R.O.
Compensated temperature range	-10 to +60°C
Safe temperature range	-20 to +80°C
Temperature effect on zero	0.1% R.O./10°C or below
Temperature effect on span	0.1% R.O./10°C or below
Input resistance	Approx. 400 Ω
Output resistance	Approx. 350 Ω
Recommended excitation voltage	10 V
Maximum excitation voltage	20 V
Insulation resistance (DC 50 V)	2000 M Ω or more
Cable	ϕ 6 4-conductor flexible cable 3 m Cable end: 5 wires
Load cell material	Stainless steel
RoHS directives	2011/65/EU (EU)2015/863

Application example

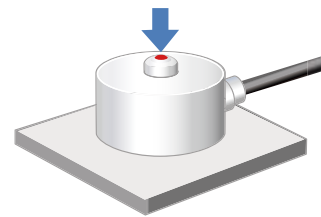

Wiring diagram

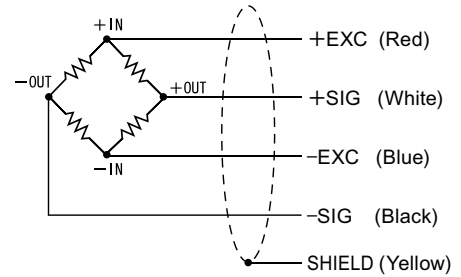

External dimension

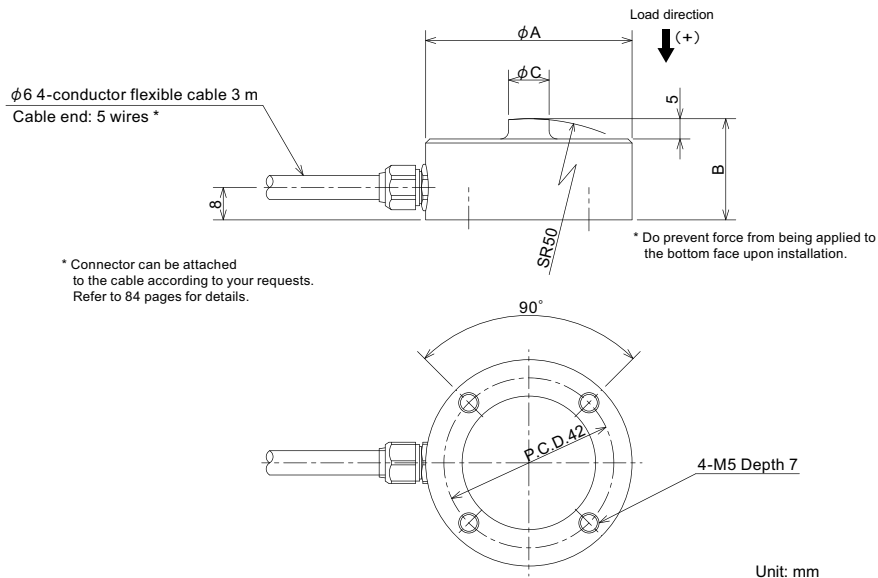

Model	Deflection at rated	Natural frequency	Weight	ϕ A	B	ϕ C
UNGS-1KN	0.040 mm	6 kHz	260 g	51	25	10
UNGS-2KN	0.045 mm	8 kHz				
UNGS-5KN	0.040 mm	13 kHz				
UNGS-10KN	0.045 mm	16 kHz	330 g	52	30	12
UNGS-20KN	0.050 mm	23 kHz				