

RSCC

TENSION TYPE LOAD CELL

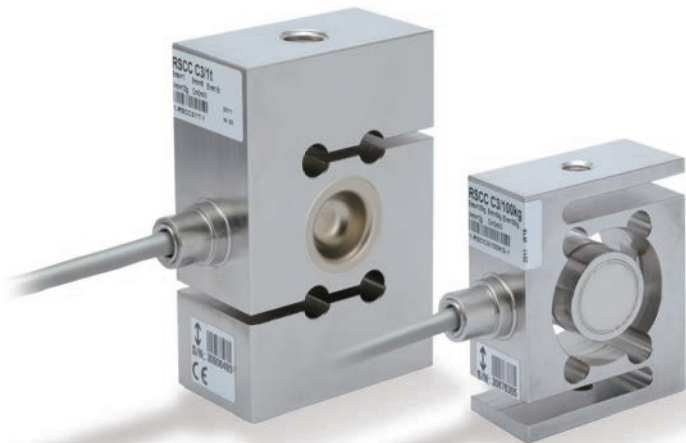

IP68

Specifications

Model	RSCC-50KG, RSCC-100KG, RSCC-200KG, RSCC-500KG, RSCC-1T, RSCC-2T, RSCC-5T	
Rated capacity	50kg, 100kg, 200kg, 500kg, 1t, 2t, 5t	
Rated output	2±0.25%	mV/V
Safe overload	150	%R.C.
Zero balance	0 ± 0.1	mV/V
Non-linearity	0.0166	%R.O.
Hysteresis	0.0166	%R.O.
Creep	0.0166	%R.O./30min
Compensated temperature range	-10 to +40	°C
Safe temperature range	-30 to +70	°C
Temperature effect on zero	0.0166	%R.O./10°C
Temperature effect on span	0.0170(+20 to +40°C) 0.0110(-10 to +20°C)	%R.O./10°C
Input resistance	389 ± 15	
Output resistance	350 ± 1.5	
Recommended excitation voltage	5	V
Maximum excitation voltage	12	V
Insulation resistance	2000 or more	M
Degrees of protection	IP68	
Cable	φ5.4 6 conductor shield cable 7.6m End treatment 7 leads.	
Load cell material	Stainless steel	

Wiring Diagram

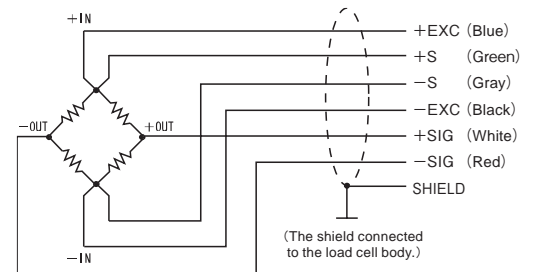

External dimension

■ RSCC-50KG to 200KG

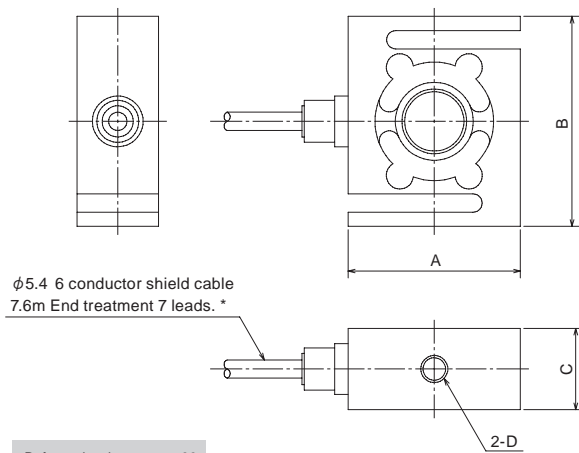

Refer to drawing at page 69 when rod end is installed.

Model	Deflection at rated	Weight	A	B	C	D
RSCC-50KG	0.35mm	0.7kg	50.8	62	24	M8 Depth 8MAX
RSCC-100KG	0.4mm	0.7kg	50.8	62	24	M8 Depth 8MAX
RSCC-200KG	0.35mm	1.0kg	57.2	87.3	24	M12 Depth 20MAX

■ RSCC-500KG to 5T

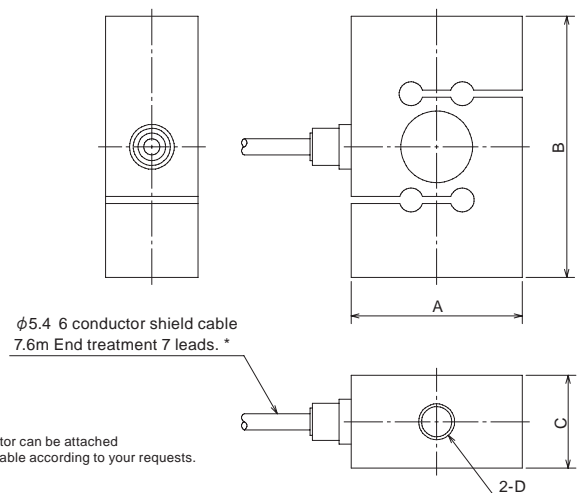

* Connector can be attached to the cable according to your requests.

Unit : mm

Model	Deflection at rated	Weight	A	B	C	D
RSCC-500KG	0.1mm	1.4kg	57.2	87.3	31	M12 Depth 19MAX
RSCC-1T	0.2mm	1.4kg	57.2	87.3	31	M12 Depth 19MAX
RSCC-2T	0.2mm	1.7kg	69.8	100	31	M24x2 Depth 29MAX
RSCC-5T	0.4mm	2.2kg	76.2	100	36.5	M24x2 Depth 24MAX